



Cleaning



Tablets



Pumps



Ancillaries



Technical data sheet APC19



- Ergonomic design for simple retrofit
- Fitted in seconds
- Incremental 'Click-lock' adjustment
- U.K. manufactured
- Robust ABS plastic construction



Statutory regulations require a minimum 19mm per metre slope to above ground condensate drains.

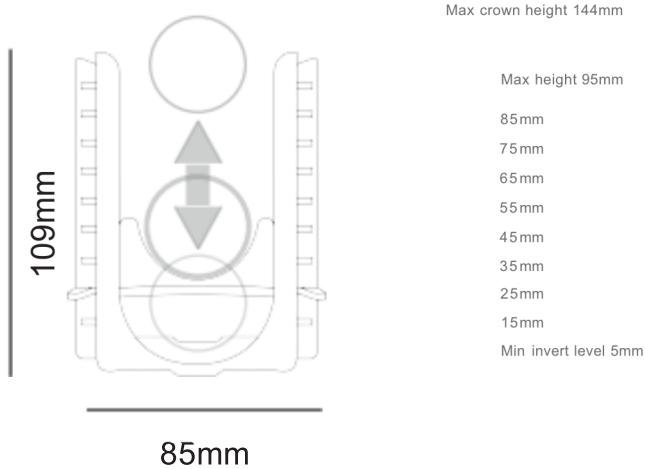

The Gel-clear APC19 is part of the bio-beta range of products for food retail refrigeration. A retrofit, adjustable pipe support for condensate drains running beneath chillers. Locks in place incremental slope settings. Statutory regulation requires a 19mm per metre slope on overground condensate drains.

Push-Pull installation for retrofitting to existing chiller drains

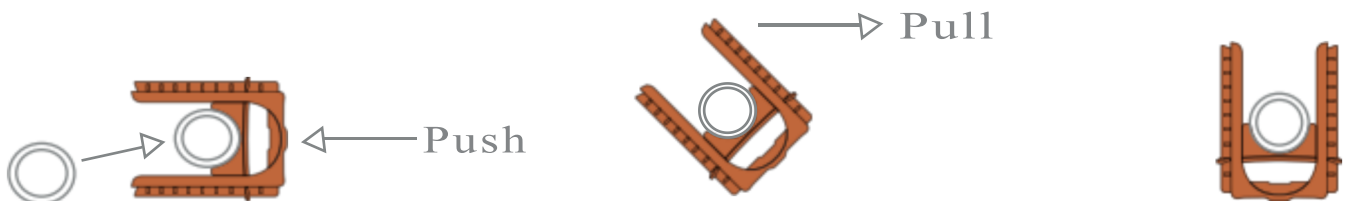

Fitted in seconds, the pipe support can be set at 10mm increments prior to fitting bringing BSEN12056 compliant sloping to flat drains.

Pipe Support Cut Down
QR Code



User Guide
QR Code

